

LR TECHNOLOGIES

12902 S. Spring Street, Los Angeles CA 90061
 Phone: 800-574-2748
 Fax: 323-770-0105



Updated 1/15/05

SPECS:

(based upon 25°C/50% RH ambient)

Temperature Range	20° - 60°C
Temperature Control	±0.2°C
Temperature Uniformity	±0.7°C
Ambient Temperature Tolerance	10°C - 28°C
Control Sensitivity	0.1°C
Control Read Out	Actual and Set-Point Values
Sensor	NIST traceable Platinum RTD
Controllers	Microprocessor PID
Calibration Capability	Actual and Set Values
Humidity Range	Ambient - 90%
Humidity Range with Optional Dehumidification	15-90%
Control of Humidity at Sensor	±0.5%
Humidity Uniformity	±1.0%
Incubator Alarm	Audible and Visible
Alarm Type	Absolute Hi/Lo in 0.1°
Remote Monitoring	Available
Electrical Requirements	115v, 60 Hz, 12 amps
Interior Cubic Feet	52
Required Clearance	1" All Sides

CABINET CONSTRUCTION:

- Exterior - 300 series stainless steel front, shroud and doors. 300 series stainless steel exterior ends, top, back, and bottom.
- Interior - 300 series stainless steel interior cabinet side walls, back, door liner and floor. Construction of liner in accordance with NSF standards.
- Cabinet mounted on a welded, galvanized frame rail, painted for additional corrosion protection.
- Frame rail fitted with 4" diameter casters, front casters include brakes).

DOORS:

- 300 series stainless steel exterior with white aluminum interior to match cabinet liner. Doors extend full width of cabinet shell. Door gaskets of one piece construction.
- Lifetime guaranteed adjustable torsion type closure system with aluminum block supports. The face of each door fitted with a 12" long recessed handle with sheetmetal interlock. Handles are foamed-in-place to insure permanent attachment. Barrel lock standard for each door. Locks keyed alike.

INSULATION:

- Entire cabinet structure and doors insulated using foamed-in-place CFC free polyurethane foam.

SHELVING:

- Adjustable vinyl coated wire shelves (3 per door). Shelves capable of supporting up to 250 lbs.
- Full height shelf support pilasters, with double oblong holes on 1/2" centers. Pilasters made of the same material as cabinet interior. Four (4) chrome plated, stainless steel shelf clips to be included for each shelf.

LIGHTING:

- Incandescent interior lighting. Light(s) activated by rocker switch mounted above door(s).

COOLING SYSTEM:

- Top mounted, thermoelectric cooling system.
- Peltier based technology is solid state, highly efficient, and reliable.
- Semi-Redundant cooling capability.
- Cooling surfaces act as dehumidifying modules at 25°C/60%RH and 30°C/65%RH

HUMIDITY CONTROL:

- NIST traceable Vaisala humidity sensor with certificate.
- Solid State controlled, Ultrasonic humidifier with ceramic/titanium disk for long life.

ELECTRICAL CHARACTERISTICS:

- Unit completely pre-wired at factory, and ready for final connection to a 115/60/1 phase - 15 amp

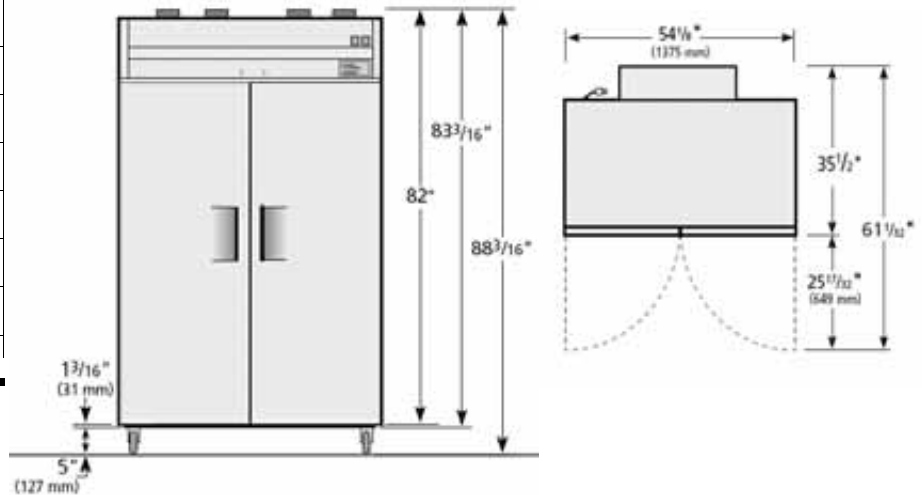

ROUGH-IN DATA

Model #	Doors	Capacity	# of Shelves	Length	Depth	Height	Phase	Amps	Nema	Cord Length	Crated Weight
LR-PH052	2	52 Cu. Ft.	6	54.1" 137.5cm	35.5" 90cm	88.2" 224cm	1	12	5-15	9'	420 lbs.