

LR TECHNOLOGIES

12902 S. Spring Street, Los Angeles CA 90061

Phone: 800-574-2748

Fax: 323-770-0105

Updated 2/05/05

SPECS:

(AT 25°C / 50%RH)

Temperature Range	4° - 60°C
Temperature Control	±0.2°C
Temperature Uniformity	±1.0°C
Ambient Temperature Tolerance	17°C - 30°C
Control Sensitivity	0.1°C
Control Read Out	Actual and Set-Point Values
Temperature Sensor	NIST Traceable Platinum RTD
Controllers	Microprocessor Based PID
Calibration Capability	Yes, Actual and Set Values
Humidity Range	Ambient - 90% @ 25°C
Humidity Range with Optional Dehumidifica-	15-90% @ 25°C
Humidity Sensor	Vaisala NIST trace-
Control of Humidity at Sensor	±0.5%
Humidity Uniformity	±2.0%
Incubator Alarm	Audible and Visible
Alarm Type	Absolute Hi/Lo in
Remote Monitoring	Available
Electrical Requirements	115v, 60 Hz, 14 amps
Interior Cubic Feet	56
Required Clearance	1" All Sides

CABINET CONSTRUCTION:

- 300 series stainless steel exterior with 300 series stainless steel interior to match cabinet liner. Doors extend full width of cabinet shell.
- Barrel lock standard for each door. Locks keyed alike.
- Cabinet mounted on a welded, galvanized frame rail, painted for additional corrosion protection.
- Frame rail fitted with 4" diameter casters, front casters include brakes).

DOORS:

- 300 series stainless steel exterior with interior to match cabinet liner. Doors extend full width of cabinet shell. Door gaskets of one piece construction.
- Lifetime guaranteed adjustable torsion type closure system with aluminum block supports. The face of each door fitted with a 12" long recessed handle with sheetmetal interlock. Handles are foamed-in-place to insure permanent attachment.
- Glass doors available.

INSULATION:

- Entire cabinet structure and doors insulated using foamed-in-place CFC free polyurethane foam.

SHELVING:

- Adjustable chrome plated stainless wire shelves (3 per door). Shelves capable of supporting up to 250 lbs.

LIGHTING:

- Incandescent interior lighting. Light(s) activated by rocker switch mounted above door(s).

REFRIGERATION SYSTEM:

- Refrigeration system factory balanced using CFC free 134A refrigerant with top mounted condensing unit.
- Factory pre-engineered capillary tube system with oversized condenser and evaporator to reduce product pull down time and to consistently maintain interior cabinet temperature (non-adjustable capillary tube system superior to problematic expansion valve). Evaporator - epoxy coated at the time of manufacture to eliminate the potential of corrosion.
- Unsurpassed temperature control through continuous refrigeration bypass system.

HUMIDITY

- Humidity control via microprocessor controlled ultrasonic humidification. Sensor is Vaisala, NIST traceable, w/cert.

ELECTRICAL CHARACTERISTICS:

- Unit completely pre-wired at factory, and ready for final connection to a 115/60/1 phase - 15 amp dedicated outlet. A cord and plug set to be included.
- A sole use circuit is required.

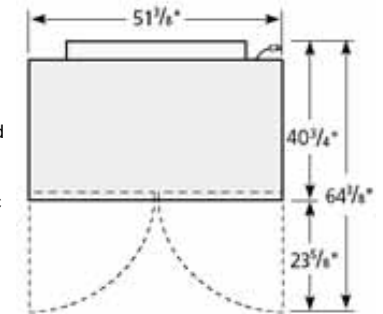
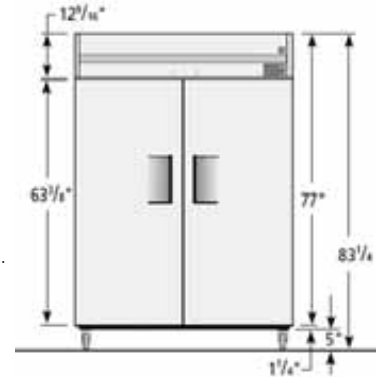

ROUGH-IN DATA

Model #	Doors	Capacity	# of Shelves	Length	Depth	Height	Phase	Amps	Nema	Cord Length	Crated Weight
LR-KB056	2	56 Cu. Ft.	6	51.4" / 130cm	40.75" / 104cm	83.3" / 211cm	1	14	5-15	9'	440 lbs.