

# LR TECHNOLOGIES

12902 S. Spring Street, Los Angeles CA 90061  
 Phone: 800-574-2748  
 Fax: 323-770-0105



Updated 1/22/05

**SPECS:**

(AT 25 °C/50% RH)

Temperature Range	Ambient +5° - 60°C
Temperature Control	±0.2°C
Temperature Uniformity	±1.0°C
Ambient Temperature Tolerance	17°C - 30°C
Control Sensitivity	0.1°C
Control Read Out	Actual and Set-Point Values
Sensor	NIST traceable Platinum RTD
Controller	Microprocessor based PID
Calibration Capability	Yes, actual and set values
Incubator Alarm	Audible and visible
Alarm Type	Absolute Hi/Lo in 0.1°C increments
Remote Monitoring	Available
Electrical Requirements	115v, 60 Hz, 16 amps
Interior Cubic Feet	74
Required Clearance	1" all sides

**CABINET CONSTRUCTION:**

- 300 series stainless steel front grill, shroud and doors. Anodized quality aluminum exterior ends and back.
- Interior - INSF approved, white vinyl coated aluminum and 300 series stainless floor with coved corners.
- Barrel lock standard for each door. Locks keyed alike.
- Cabinet mounted on a welded, galvanized frame rail, painted for additional corrosion protection.
- Frame rail fitted with 4" diameter casters, front casters include brakes.

**DOORS:**

- 300 series stainless steel exterior with white aluminum interior to match cabinet liner. Doors extend full width of cabinet shell.
- Door gaskets of one piece construction.
- Glass doors available.
- Lifetime guaranteed adjustable torsion type closure system with aluminum block supports.
- The face of each door fitted with a 12" long recessed handle with sheetmetal interlock. Handles are foamed-in-place to insure permanent attachment.

**INSULATION:**

- Entire cabinet structure and doors insulated using foamed-in-place CFC free polyurethane foam.

**SHELVING:**

- Adjustable vinyl coated wire shelves (3 per door). Shelves capable of supporting up to 250 lbs.
- Full height shelf support pilasters, with double oblong holes on 1/2" centers. Pilasters made of the same material as cabinet interior. Four (4) chrome plated, stainless steel shelf clips to be included for each shelf.

**LIGHTING:**

- Incandescent interior lighting. Light(s) activated by rocker switch mounted above door(s).

**ELECTRICAL CHARACTERISTICS:**

- Unit completely pre-wired at factory, and ready for final connection to a 115/60/1 phase - 20 amp dedicated outlet.
- A cord and plug set to be included.
- A sole use circuit is required.

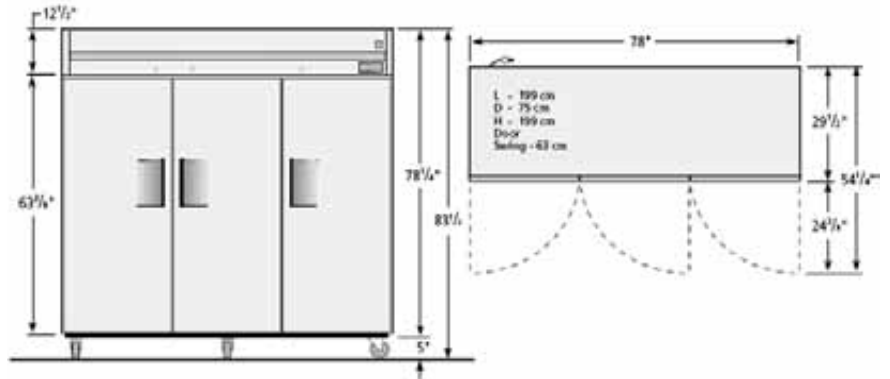

## ROUGH-IN DATA

Model #	Doors	Capacity	# of Shelves	Length	Depth	Height	Phase	Amps	Nema	Cord Length	Crated Weight
H74	3	74 Cu. Ft.	9	78" 199cm	29.5" 75cm	83.2" 211.5cm	1	16	5-20	9'	500 lbs.