

LR TECHNOLOGIES

12902 S. Spring Street, Los Angeles CA 90061
 Phone: 800-574-2748
 Fax: 323-770-0105



Updated 1/22/05

SPECS:

Temperature Range	4° - 60°C
Temperature Control	±0.2°C
Temperature Uniformity	±1.0°C
Ambient Temperature Tolerance	17°C - 30°C
Control Sensitivity	0.1°C
Control Read Out	Actual and Set-Point Values
Sensor	NIST traceable platinum RTD
Controller	Microprocessor based PID
Calibration Capability	Yes, actual and set values
Incubator Alarm	Audible and visible
Alarm Type	Absolute Hi/Lo in 0.1°C increments
Remote Monitoring	Available
Electrical Requirements	115v, 60 Hz, 12 amps
Interior Cubic Feet	52
Required Clearance	1" all sides

CABINET CONSTRUCTION:

- 300 series stainless steel front grill, shroud and doors. Anodized quality aluminum exterior ends and back.
- Interior - INSF approved, white vinyl coated aluminum and 300 series stainless floor with coved corners.
- Barrel lock standard for each door. Locks keyed alike.
- Cabinet mounted on a welded, galvanized frame rail, painted for additional corrosion protection.
- Frame rail fitted with 4" diameter castors, (front castors include brakes).

DOORS:

- 300 series stainless steel exterior with interior to match cabinet liner. Doors extend full width of cabinet shell. Door gaskets of one piece construction.
- Lifetime guaranteed adjustable torsion type closure system with aluminum block supports. The face of each door fitted with a 12" long recessed handle with sheetmetal interlock. Handles are foamed-in-place to insure permanent attachment.
- Glass doors available.

INSULATION:

- Entire cabinet structure and doors insulated using foamed-in-place CFC free polyurethane foam.

SHELVING:

- Adjustable vinyl coated wire shelves (3 per door). Shelves capable of supporting up to 250 lbs.
- Full height shelf support pilasters, with double oblong holes on 1/2" centers. Pilasters made of the same material as cabinet interior.

LIGHTING:

- Incandescent interior lighting. Light(s) activated by rocker switch mounted above door(s).

REFRIGERATION SYSTEM:

- Refrigeration system factory balanced using CFC free 134A refrigerant.
- Top mounted condensing unit.
- Factory pre-engineered capillary tube system with oversized condenser and evaporator to reduce product pull down time and to consistently maintain interior cabinet temperature (non-adjustable capillary tube system superior to problematic expansion valve).
- Evaporator - epoxy coated at the time of manufacture to eliminate the potential of corrosion.
- Unsurpassed temperature control through continuous refrigeration bypass system.

ELECTRICAL CHARACTERISTICS:

- Unit completely pre-wired at factory, and ready for final connection to a 115/60/1 phase - 15 amp dedicated outlet. A cord and plug set to be included.

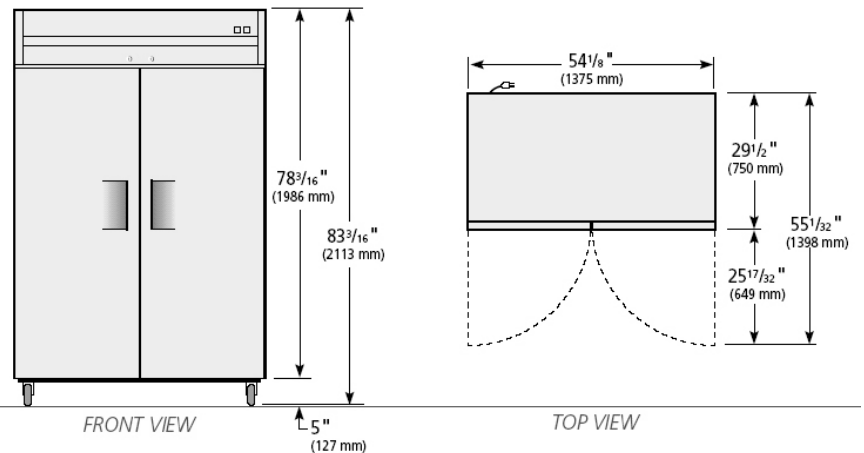

ROUGH-IN DATA

Model #	Doors	Capacity	# of Shelves	Length	Depth	Height	Phase	Amps	Nema	Cord Length	Crated Weight
DB052	2	52 Cu. Ft.	6	54.1" 137.5cm	29.5" 75cm	83.2" 211.3cm	1	12	5-15	9'	420 lbs.

• A sole use circuit is required.