

LR TECHNOLOGIES

12902 S. Spring Street, Los Angeles CA 90061

Phone: 800-574-2748

Fax: 323-770-0105



Updated 1/23/05

SPECS:

Temperature Range	4° - 60°C
Temperature Control	±0.2°C
Temperature Uniformity	±1.0°C
Ambient Temperature Tolerance	17°C - 30°C
Control Sensitivity	0.1°C
Control Read Out	Actual and Set-Point Values
Sensor	NIST Traceable Platinum-RTD
Controller	Microprocessor based PID
Calibration Capability	Yes, actual and set
Incubator Alarm	Audible and visible
Alarm Type	Absolute Hi/Lo in 0.1°C increments
Remote Monitoring	Available
Electrical Requirements	115v, 60 Hz, 10 amps
Interior Cubic Feet	31
Required Clearance	1" all sides

CABINET CONSTRUCTION:

- Exterior - 300 series stainless steel front, shroud and doors. 300 series stainless steel exterior ends, top, back, and bottom.
- Interior - 300 series stainless steel interior cabinet side walls, back, door liner and floor. Construction of liner in accordance with NSF standards.

- Barrel locks standard. Locks keyed alike.

- Cabinet mounted on a welded, galvanized frame rail, enamel dipped and baked for permanent bond on all surfaces, provides additional corrosion protection. Frame rail fitted with 4" diameter polyolefin casters, (front casters include brakes).

DOORS:

- 300 series stainless steel exterior with 300 series stainless steel interior to match cabinet liner. Doors extend full width of cabinet shell. Door gaskets of one piece construction. Glass doors available.

- Lifetime guaranteed adjustable torsion type closure system with extruded aluminum and stainless steel supports. The face of each door fitted with a 12" long recessed handle with interlock (lifetime guarantee on all handles and door hardware). Handles are foamed-in-place to insure permanent attachment.

INSULATION:

- Entire cabinet structure and doors insulated using foamed-in-place CFC free polyurethane foam.

SHELVING:

- Adjustable wire shelves (3 per door). Shelves capable of supporting up to 250 lbs.

LIGHTING:

- Incandescent interior lighting. Light(s) activated by rocker switch mounted above door(s).

REFRIGERATION SYSTEM:

- Unsurpassed temperature control through continuous refrigeration bypass system.
- Refrigeration system factory balanced using CFC free 134A refrigerant.
- Top mounted condensing unit.
- Factory pre-engineered capillary tube system with oversized condenser and evaporator to reduce product pull down time and to consistently maintain interior cabinet temperature (non-adjustable capillary tube system superior to problematic expansion valve).

- Evaporator - epoxy coated at the time of manufacture to eliminate the potential of corrosion.

ELECTRICAL CHARACTERISTICS:

- Unit completely pre-wired at factory, and ready for final connection to a 115/60/1 phase - 15 amp

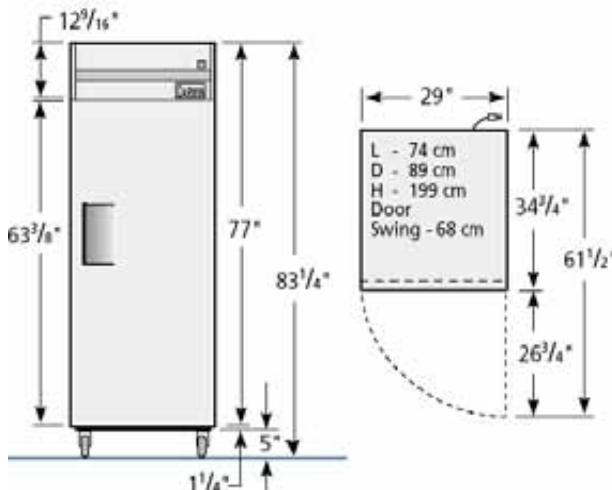

ROUGH-IN DATA

Model #	Doors	Capacity Cu. Ft./L	# of Shelves	Length	Depth	Height (no casters)	Phase	Amps @ 115 V	Nema	Cord Length	Crated Weight
DB031	1	31 Cu. Ft.	3	29"	34 3/4"	78 1/4"	1	10	5-15P	9'	320 lbs.